

Premium Inspection Door

PRODUCT
FACT
SHEET

The range of TS global inspection doors provide a safe inspection point for access to cleaners and chute. Our inspection doors are simple to install and allow easy access for maintenance and service.

Application

Installed in any conveyor chute.

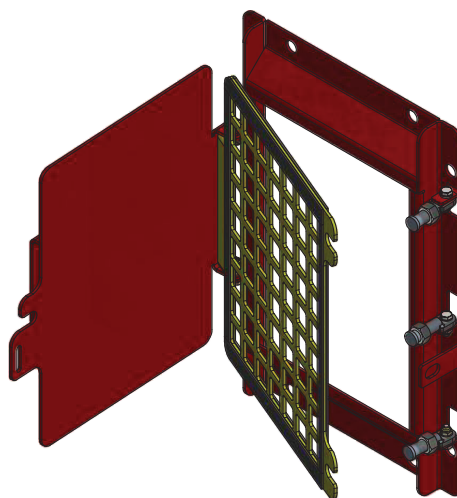

-  Proven Performance
-  Quality Product
-  Flexibility in Design
-  On-time Delivery

| FEATURES | | BENEFITS |
|----------------------|---|---|
| Easy to use | = | Allows safe inspection of cleaners |
| Effective seal | = | Retains dust within confines of the transfer chute |
| Safety mesh | = | Improves accessibility for inspection or adjustment while conveyor is running |
| Available in 3 sizes | = | Flexible to use |
| Hinged safety mesh | = | Allows access for maintenance |