

Pressure Roller Assembly

PRODUCT
FACT
SHEET

The TS Global pressure roller assembly kit is guaranteed to provide a flat and stable surface that optimises and maintains cleaner tip contact and performance.

This is achieved by increasing belt stability, maintaining tip-to-belt contact, adding flexibility and generally improving belt cleaning efficiency by reducing belt vibration and harmonics.

Balancing cost effectiveness with long life functionality makes this the ideal choice for your application.

Application

All belt cleaning systems.

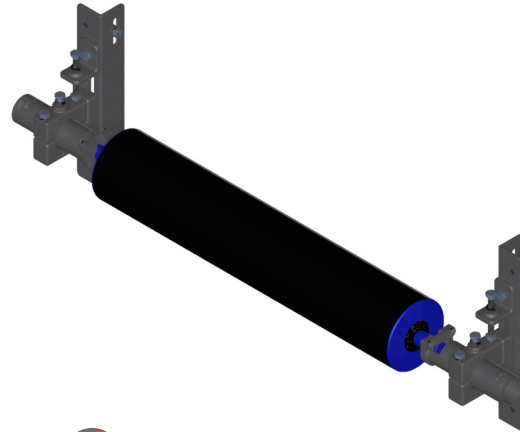

 Proven Performance

 Quality Product

 Flexibility in Design

 On-time Delivery

FEATURES	BENEFITS
Designed with roller locking plate	<ul style="list-style-type: none"> = Retains rollers in position during operations or when belt tension is removed = Reduces potential fall safety hazards
Manufactured from high grade stainless steel	<ul style="list-style-type: none"> = Increases longevity in structural components
Designed with adjustable roller mounts	<ul style="list-style-type: none"> = Accommodates all site rollers = Allows rollers to be backed away from the belt during belt change-out
Assembly can be retrofitted to any conveyor	<ul style="list-style-type: none"> = Guaranteed to suit our clients individual needs
Stabilises conveyor belt	<ul style="list-style-type: none"> = Promotes optimum performance of secondary belt cleaners

Pressure Roller Assembly

PRODUCT
FACT
SHEET



Item Code	Description	Unit	Weight	
			(kg)	(lbs)
22-10-001	Pressure Roller Mounting Kit suit 14 (5 1/2") AF Slots	Each	6	13
22-10-002	Pressure Roller Mounting Kit suit 22 (8 1/4") AF Slots	Each	6	13

*AF slot width can be customised to suit most site rollers.

For more information, please contact TS Global directly and/or your TS Global product distributor.

DISTRIBUTED BY

PHONE 1300 418 298 • **EMAIL** sales@tsglobal.net.au • **WEB** www.tsglobal.net.au

WELSHPOOL WA • TOMAGO NSW • MACKAY QLD

ABN 30 603 644 748