

# Dual Stabilising Roller Assembly

PRODUCT  
FACT  
SHEET

The TS Global dual stabilising roller assembly kit is guaranteed to provide a flat and stable surface that optimises and maintains cleaner tip contact and performance.

This is achieved by increasing belt stability, maintaining tip-to-belt contact, adding flexibility and generally improving belt cleaning efficiency by reducing belt vibration and harmonics.

Balancing cost effectiveness with long life functionality makes this the ideal choice for your application.

## Application

All belt cleaning systems.

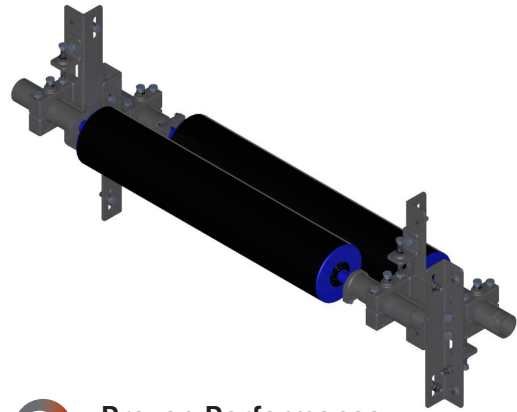

-  Proven Performance
-  Quality Product
-  Flexibility in Design
-  On-time Delivery

FEATURES	BENEFITS
Designed with roller locking plate	<ul style="list-style-type: none"> <li>= Retains rollers in position during operations or when belt tension is removed</li> <li>= Reduces potential fall safety hazards</li> </ul>
Manufactured from high grade stainless steel	<ul style="list-style-type: none"> <li>= Increases longevity in structural components</li> </ul>
Designed with adjustable roller mounts	<ul style="list-style-type: none"> <li>= Accommodates all site rollers</li> <li>= Allows rollers to be backed away from the belt during belt change out</li> </ul>
Assembly can be retrofitted to any conveyor	<ul style="list-style-type: none"> <li>= Guaranteed to suit our clients individual needs</li> </ul>
Stabilises conveyor belt	<ul style="list-style-type: none"> <li>= Promotes optimum performance of secondary belt cleaners</li> </ul>

# Dual Stabilising Roller Assembly

PRODUCT  
FACT  
SHEET



Item Code	Description	Unit	Weight	
			(kg)	(lbs)
22-11-001	Stabilising Roller Mounting Kit suit 14(5 1/2") AF Slots	Each	12	26
22-11-002	Stabilising Roller Mounting Kit suit 22(8 1 1/4") AF Slots	Each	12	26

\*AF slot width can be customised to suit most site rollers.

For more information, please contact TS Global directly and/or your TS Global product distributor.

**DISTRIBUTED BY**

**PHONE** 1300 418 298 • **EMAIL** sales@tsglobal.net.au • **WEB** www.tsglobal.net.au

**WELSHPOOL WA** • **TOMAGO NSW** • **MACKAY QLD**

ABN 30 603 644 748