

Tensioners

PRODUCT
FACT
SHEET

The market leading TS Global auto tensioner is designed to ensure a consistent tension applied to any belt cleaner at all times. The in-built accumulator and manifold react to any wear encountered and automatically adjusts to deliver optimum performance.

Balancing cost effectiveness with long life functionality makes this the ideal choice for your application.

Applications

Suitable for any TS Global belt cleaning system.

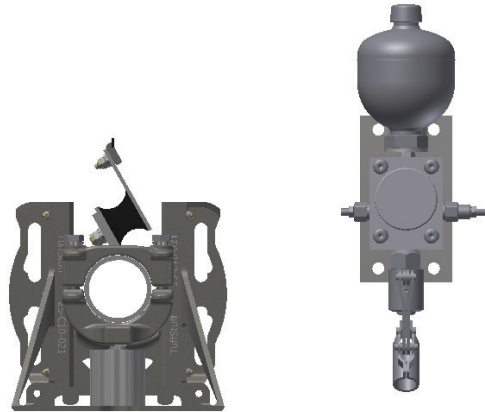

-  Proven Performance
-  Quality Product
-  Flexibility in Design
-  On-time Delivery

FEATURES	BENEFITS
Patented self-powered accumulator	<ul style="list-style-type: none"> = No external power source required = Pre-charged accumulator maintains optimum tension
Pressure regulation	<ul style="list-style-type: none"> = Allows fine tuning of cleaner tension to optimise performance
Built-in reservoir and pump	<ul style="list-style-type: none"> = Reservoir large enough to store all oil required to operate = Pump permanently mounted for ease of adjustment
Manufactured from stainless steel and aluminium	<ul style="list-style-type: none"> = Eliminates corrosion = Long lasting
Compact in design	<ul style="list-style-type: none"> = Can be installed in tight locations
Can be retro fitted to existing cleaners	<ul style="list-style-type: none"> = Minimises capital expenditure = Optimises cleaner performance

Tensioners

PRODUCT
FACT
SHEET



Item Code	Description	Unit	Weight	
			(kg)	(lbs)
17-A12-001	Auto tensioner to suit P and R Cleaners with 73mm (2 7/8 inch) pole	Each	11	24
17-A10-101	Auto tensioner to suit H Cleaners with 73mm (2 7/8 inch) pole	Each	11	24

For more information, please contact TS Global directly and/or your TS Global product distributor.

DISTRIBUTED BY

PHONE 1300 418 298 • **EMAIL** sales@tsglobal.net.au • **WEB** www.tsglobal.net.au

WELSHPOOL WA • TOMAGO NSW • MACKAY QLD

ABN 30 603 644 748

